

MP 2016a Mixer

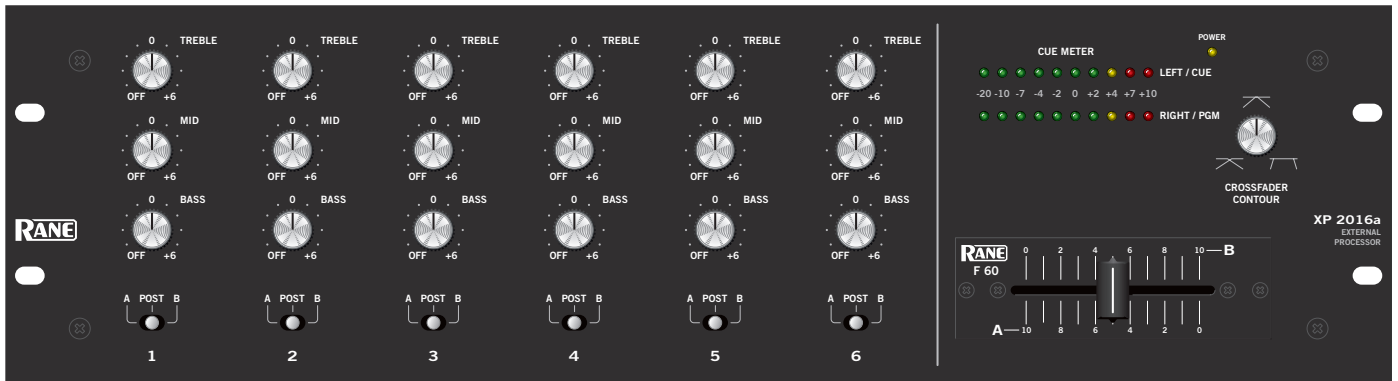

Optional **XP 2016a Processor**

MP 2016a Features

- Six stereo Input channels
- Four dedicated stereo Phono / Line preamps
- Two dedicated Mic / Line preamps with:
 - Gain trims
 - 2-band Tone controls
 - Engage switches
 - Booth ducking
- Five stereo Auxiliary Inputs
- Input Gain controls for level matching
- Switchable Effects Loop
- Booth Output with Master / Cue source switch

- Separate Pre- and Post-effects Tape Outputs
- Master *Accelerated-Slope™*, full-cut, 3-band Tone controls
- Audiophile / Studio sound quality; Uses highest-quality ALPS pots
- **NEW!** Split Cueing with high power headphone amplifier

XP 2016a Features

- *Active-Crossfader™* with full-range Contour control
- A-POST-B Crossfader assign switches
- Stereo Master / Cue Meter with peak hold
- Six channels of stereo, *Accelerated-Slope™*, full-cut, 3-band Tone controls.

MP 2016a Block Diagram

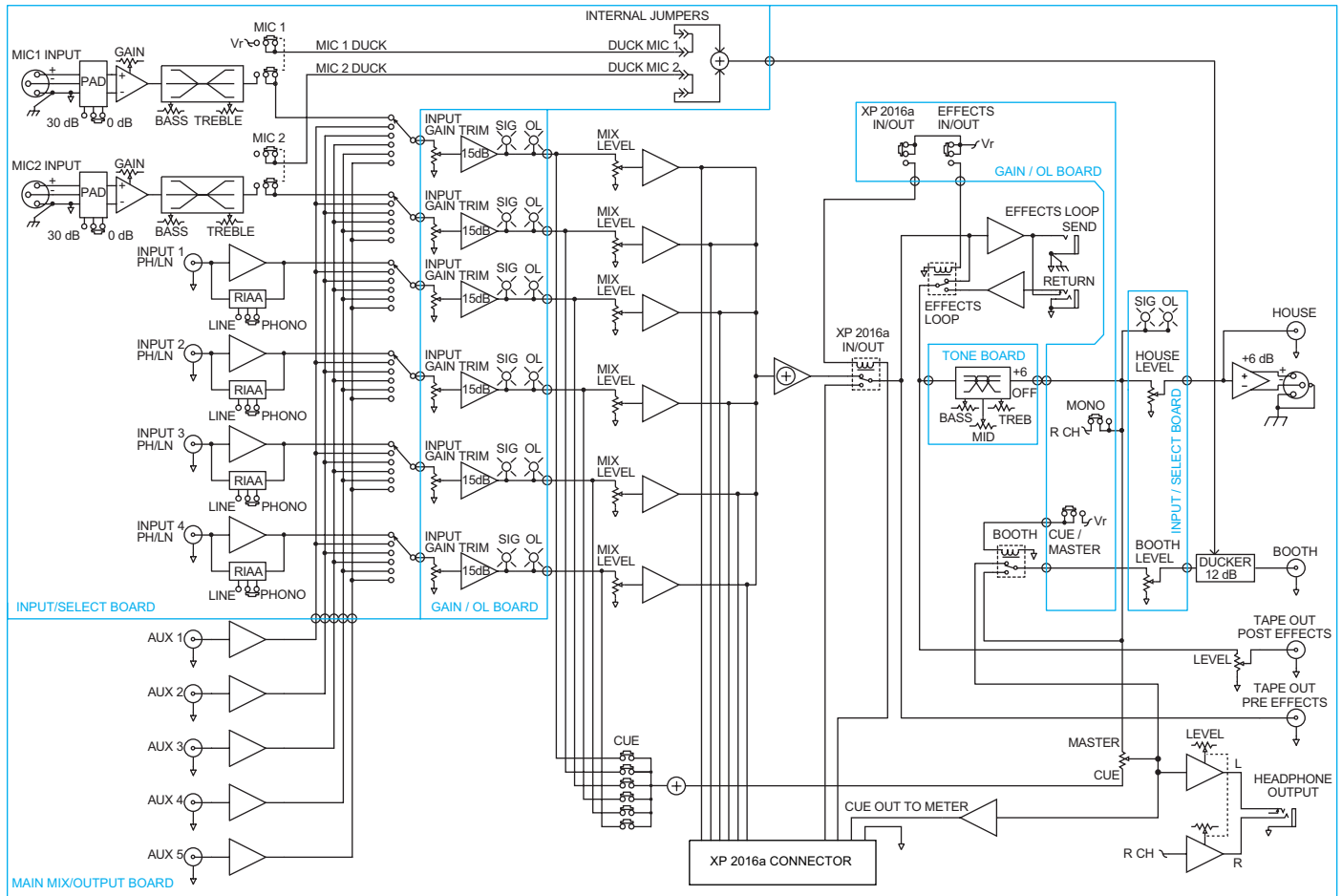

MP 2016a General Description

The MP 2016a is a rotary-controlled mixer featuring six Input Channels, Booth and House Outputs, Pre-Effects Tape Outputs, Post-Effects Tape Outputs with Level control, switchable Effects Loop, and Headphone Cueing. Input Channels 1 through 4 feature high quality RIAA phono preamplifiers which may be switched to line input via rear panel switches. Input Channels 5 and 6 each provide a balanced mic preamp with Input Gain trim, Mic/Line switch, two-band EQ, Mic Engage switch and an internal Booth Ducking enable jumper. In addition to the six dedicated preamplifiers, all six Input channels may select any of the five stereo Auxiliary Inputs.

Each Input Channel provides a 6-position source selector, Input Gain control for matching levels, Signal/Overload indicators and a studio-grade Master Mix control.

The Booth Output may select Master or Cue as its source. An ultra-low noise, high power headphone amplifier also allows monitoring the Master Mix or Cue Mix.

The MP 2016a improves on the original MP 2016 by adding Split Cue. Individual Cue switches on each channel drive a panning Master / Cue control for the Headphone output.

The Master Mix circuit provides Signal/Overload indicators, Mono switch and high-pass/rumble filters. In addition, the Master Output features patent-pending high performance 3-band, full-cut, *Accelerated-Slope™* tone controls (see page 5).

The MP 2016a provides exceptional ergonomics, good feel and a clean, intuitive layout packaged in a compact 19 inch, 3U rack mount chassis, a scant five inches deep.

XP 2016a Block Diagram

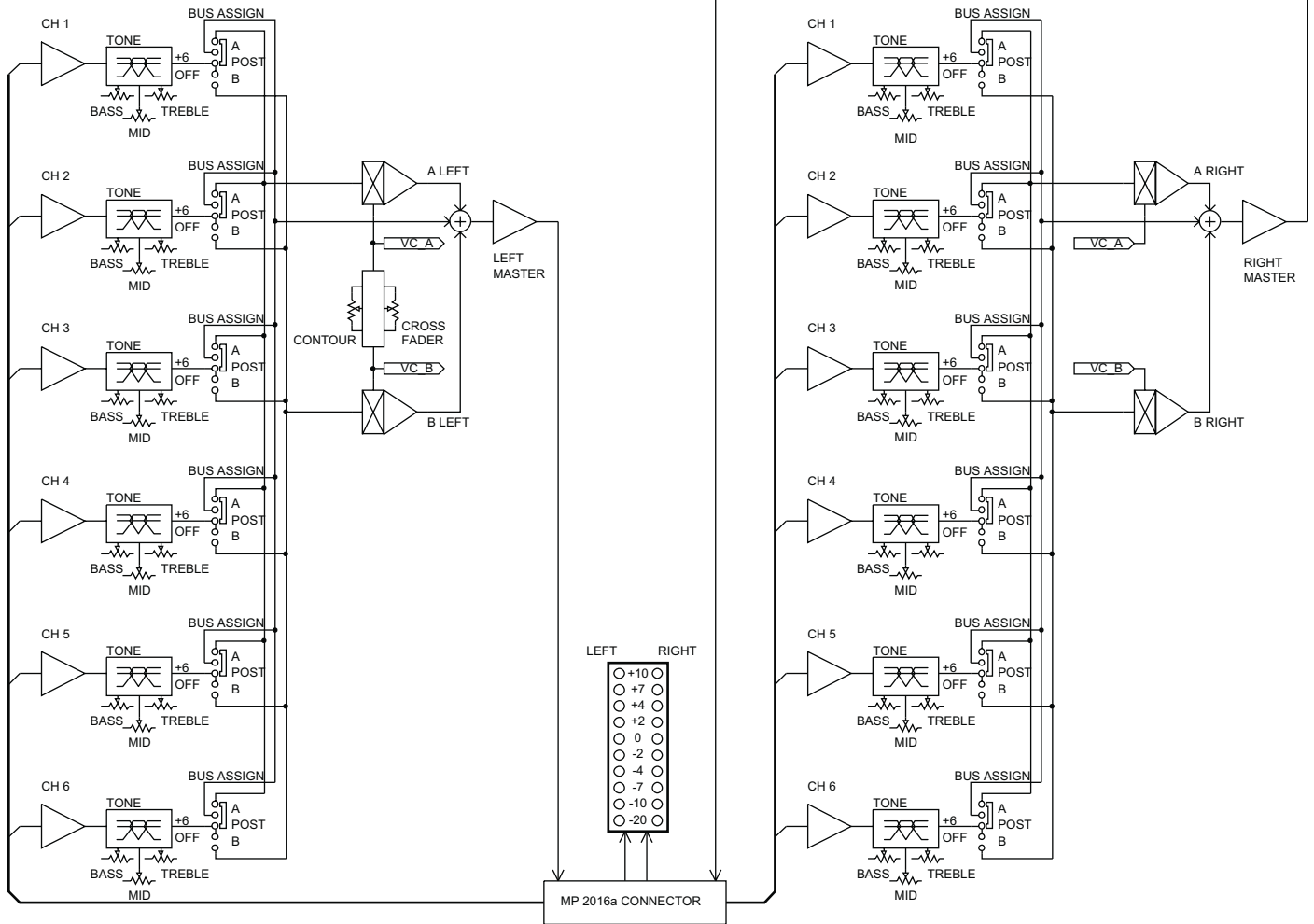

XP 2016a General Description

So you say... “Great, but to accommodate the diverse needs of all DJ mixing styles, I need dedicated high performance three-band, full-cut, *Accelerated-Slope* tone controls for *each* of the six Input Channels, high-performance *Active-Crossfader*™ with full range contour control, A-Post-B crossfader assign switches and a stereo, 10-segment, peak dBu Master/Cue meter with peak hold; all without effecting the ergonomics of my classic rotary mixer.”

We’ve got you covered! With the flip of a switch on the MP 2016a front panel, you can engage the *optional* XP 2016a External Processor and acquire all of these features.

The XP 2016a is an *optional* external processor designed specifically for use with the MP 2016a. The XP 2016a is intended to mount above or below the MP 2016a. It connects with a single 10-inch ribbon cable and is engaged with the flip of a switch on the MP 2016a front panel. If an XP 2016a is not connected, the XP 2016a engage switch on the MP 2016a has no effect.

The XP 2016a provides dedicated *Accelerated-Slope*, 3-band, full-cut tone controls for *each* of the six stereo Input channels, A-Post-B Crossfader Assign switches for all six Input channels,

a high-performance *Active Crossfader*™ with full range Contour control, and a stereo 10-segment peak dBu Master/Cue Meter with peak hold.

The six stereo, post Mix Level signals in the MP 2016a are fed to the XP 2016a. When the XP 2016a is *not* engaged, the post Mix Level signals go directly to the Master Mix in the MP 2016a. When the XP 2016a is *is* engaged, the stereo Master Mix comes from the XP 2016a.

If all Input channels on the XP 2016a are assigned Post-Crossfader, the Mix will be identical to the MP 2016a (with the addition of tone controls for each Input channel). For Crossfader control, simply assign a channel to the A or B side of the Crossfader. The *Active Crossfader* features a full-range Contour control for smooth blending or ultra fast cuts.

The Master/Cue Meter follows the source selection of the headphone monitor on the MP 2016a. If Master is selected, the XP 2016a Meter monitors the pre-house-level Master signal. If Cue is selected, the XP 2016a meter monitors the Cue Source.

The XP 2016a matches the MP 2016a ergonomics, packaged in a compact 19 inch, 3U rack mount chassis, 5 inches deep.

Crossfader Response

This graph shows curves representing upper and lower limits for gain response versus fader position. Contour controls allow smooth and continuous adjustment between the two responses.

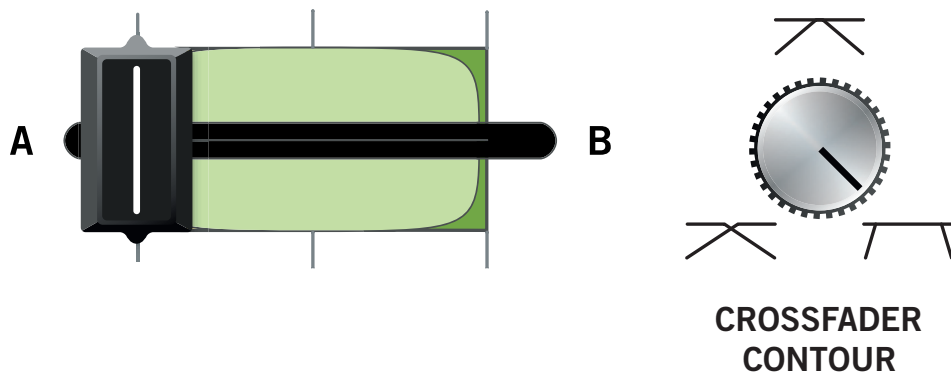
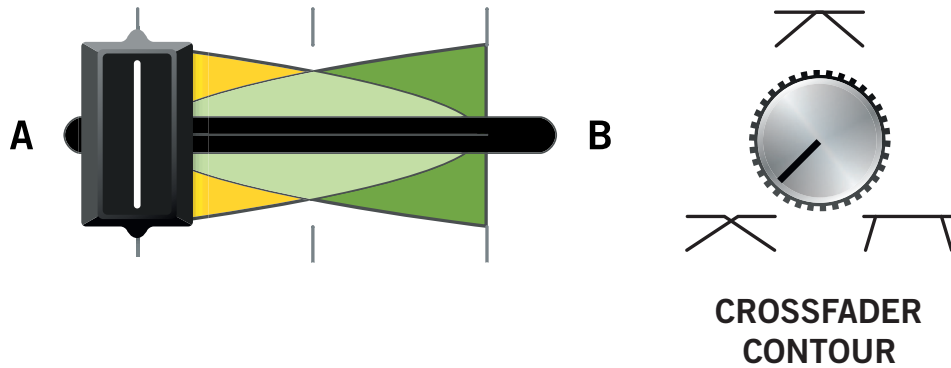
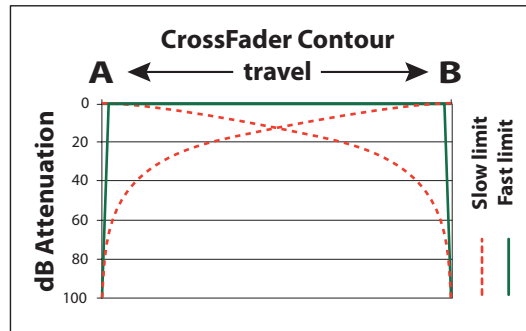

MP 2016a and XP 2016a Accelerated-Slope EQ Control Response

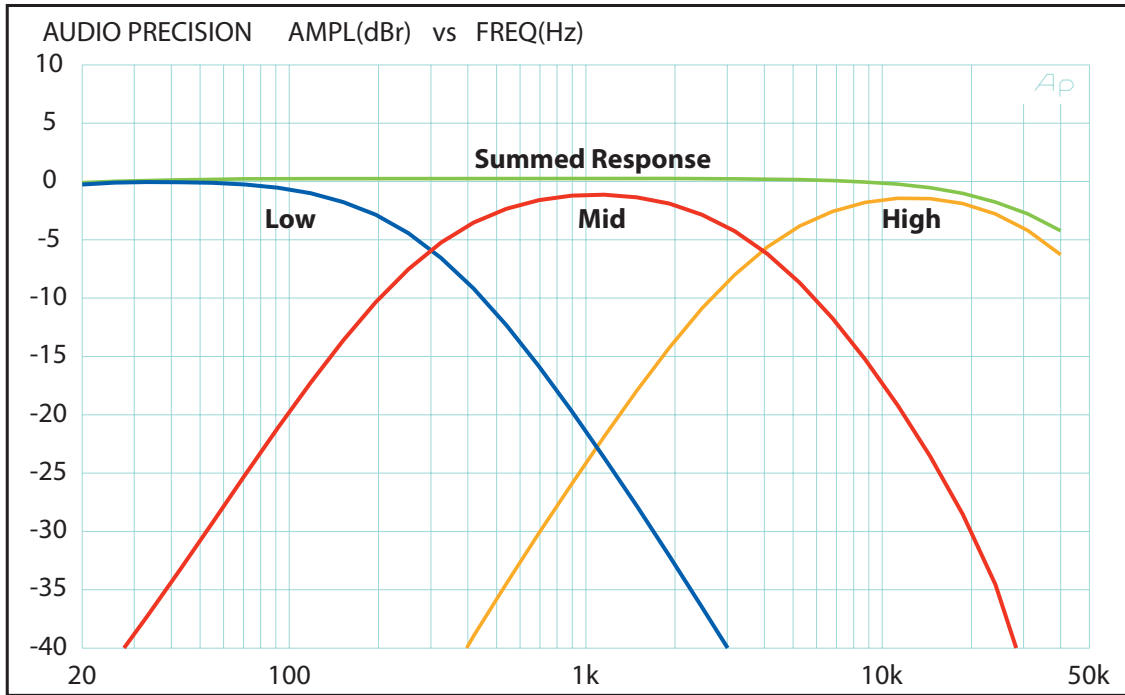

Figure 1 shows the three EQ filter bands and the flat summed response

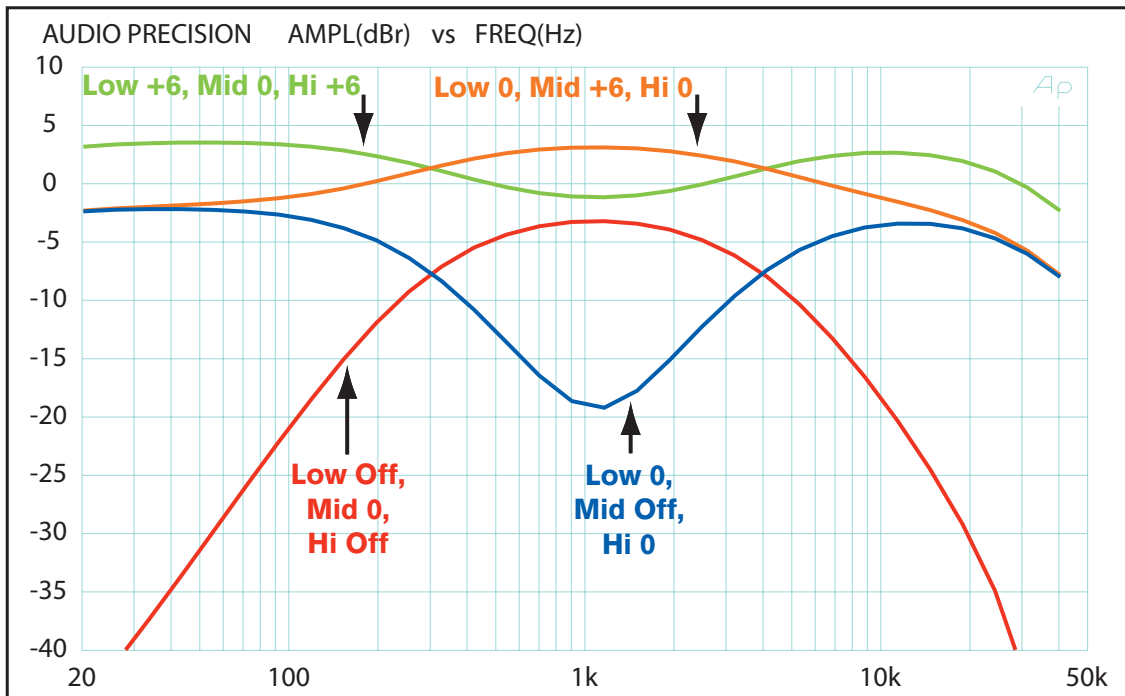

Figure 2 shows the interactive operation of the Accelerated-Slope™ EQ



MP 2016a Features and Specifications

Parameter	Specification	Limit	Units	Conditions/Comments
Gain (Unbalanced Outputs): <i>1 kHz, EQ centered, All levels max, add 6 dB for balanced output</i>				
.....Phono/Line	52 / 16	0.5	dB	
.....Aux Line	16	0.5	dB	
.....Mic/Line	66 / 36	1.5	dB	
.....XP 2016a port	0	0.5	dB	
.....House	+6	0.5	dB	
Input Impedance:				1 kHz
.....Phono/Line	47.5k	1%	Ω	Shunted by 200 pF
.....Aux Line	23k	1%	Ω	
.....Mic/Line	1.02k/29k	1%	Ω	Differential input impedance
.....Effects Return	5.11k	1%	Ω	
Max Input Level: <i>Max input before input stage overload, @ 1 kHz</i>				
.....Phono/Line	77.5	5%	mV	
.....Aux Line	+20	1	dBu	
.....Mic/Line, Max Gain	-30/0	2	dBu	
.....Mic/Line, Min Gain	0/+30	2	dBu	
Output Impedance:				@ 1 kHz
.....Balanced	150	1%	Ω	Each leg
.....Unbalanced	300 / 150	1%	Ω	Other / Booth
Max Output Levels:				@ 1 kHz
.....Balanced	+26	min.	dBu	2k Ω load
.....Unbalanced	+20	min.	dBu	2k Ω load
.....Headphone	150 / 120	min.	mW	600 / 150 Ω
Infrasonic Filter	15	5%	Hz	18 dB/octave
THD+N	.01 (Line in to unbalanced output)	typ.	%	20 to 20 kHz, 80 kHz BW
Signal-to-Noise Ratio: <i>Input gain set for unity, Tones set flat; Any one mix set to max (all others min), any unbalanced out.</i>				
.....Phono	91	1	dBu	Input shorted, "A" weighted
.....Mic	60 (Mic Gain max, Input Gain max)	1	dBu	Input terminated with 150 Ω
.....Line	94	1	dBu	Input terminated with 150 Ω
Signal Indicators: SIG / OL	-2 / +18	1	dBu	
Crosstalk	-70	max.	dB	Channel to channel, 1 kHz
Control Feed-through	-80	max.	dB	1 kHz
Master Tone Controls: Treble	4k, Shelving	5%	Hz	2nd-order, range +6 dB to full kill
.....Mid	300 to 4k, Band-pass	5%	Hz	2nd-order, range +6 dB to full kill
.....Bass	300, Shelving	5%	Hz	2nd-order, range +6 dB to full kill
Microphone Tone Controls:				
.....Bass	100, Shelving	5%	Hz	Range ±12 dB
.....Treble	5k, Shelving	5%	Hz	Range ±12 dB
Note: 0 dBu=0.775 Vrms				

XP 2016a Features and Specifications

Parameter	Specification	Limit	Units	Conditions/Comments
Gain	0	1	dB	1 kHz, tone flat
Input Impedance	20k	1%	Ω	1 kHz
Max Input Level	+20	min	dBu	Max before input stage overload @ 1 kHz
Output Impedance	100	1%	Ω	@ 1 kHz
Max Output Levels	+20	min	dBu	@ 1 kHz
THD+N: Post Crossfader	.01	typ	%	20 to 20 kHz, 80 kHz BW
.....Crossfader	.1	typ	%	20 to 20 kHz, 80 kHz BW
Noise	-82	1	dBu	Tones set flat
Meters: Type	Peak dBu			Follows MP 2016a Headphone source
Crossfader: Type	Active with Contour control			
Crosstalk	-70	max	dBu	Channel to channel, 1 kHz
Control Feed-through	-80	max	dB	1 kHz
Tone Controls: Treble	4k, Shelving	5%	Hz	2nd-order, range +6 dB to full kill
.....Mid	300 to 4k, Band-pass	5%	Hz	2nd-order, range +6 dB to full kill
.....Bass	300, Shelving	5%	Hz	2nd-order, range +6 dB to full kill
<i>Note: 0 dBu=0.775 Vrms</i>				

Agency, Power and Shipping Specifications

Parameter	Specification	Limit	Units	Conditions/Comments
Unit: Agency Listing				
.....120 VAC model	Class 2 Equipment UL, CSA			National Electrical Code Exempt, Class 2
.....230 VAC model	VDE, SELV CE (EMC) CE (safety) Exempt			Safety extra low voltage EMC directive 89/336/EEC Article 1 of LVD 73/23/EEC
Power Supply: Agency Listing				Class 2 equipment
.....120 VAC model	UL listed CSA Certified			File no. E88261 File no. LR58948
.....230 VAC model	CE (EMC) CE (safety)			Meets EMC directive 89/336/EEC LV directive 73/23/EEC
Power Supply Requirement	18 VAC w/ center tap			RS 1
Maximum Current	750		mA	RMS current from remote supply
Unit Construction	All Steel			
.....Size	5.25"H x 19"W x 5.3"D (3U)			(13.3 cm x 48.3 cm x 13.5 cm)
.....Weight	11 lb			(5.0 kg) Each Unit
Shipping: Size	11" x 23" x 16"			(27.9 cm x 58.4 cm x 40.6 cm)
.....Weight	18 lb			(8.1 kg) Each Unit

MP 2016a Rear Panel

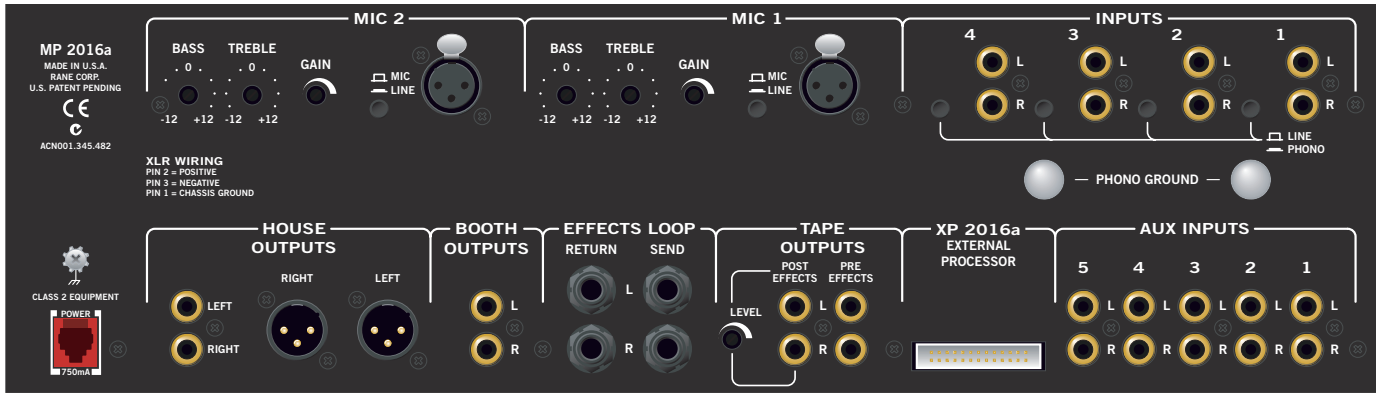

XP 2016a Rear Panel

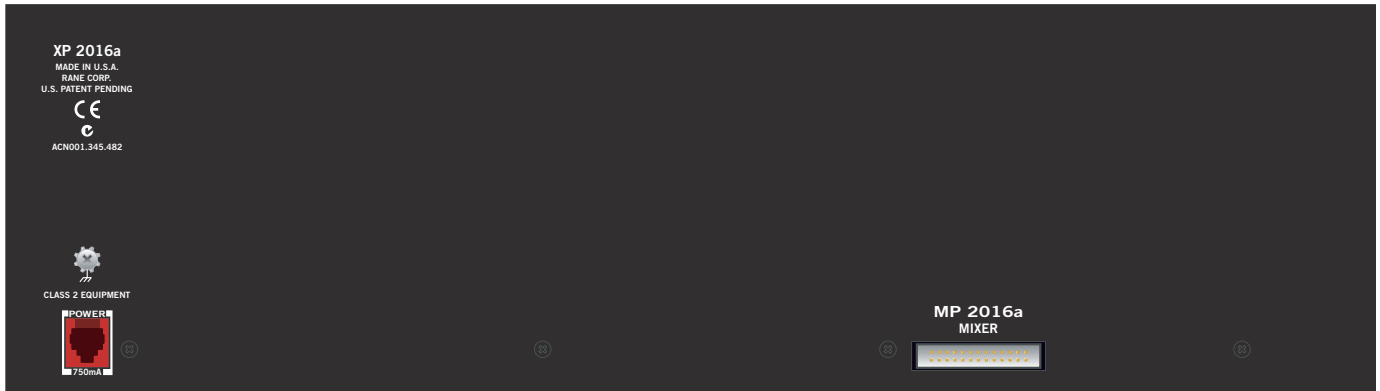

XP 2016a Accessories

- F 45 Fader Kit - 45 mm Crossfader Replacement
- F 60 Fader Kit - 60 mm Crossfader Replacement

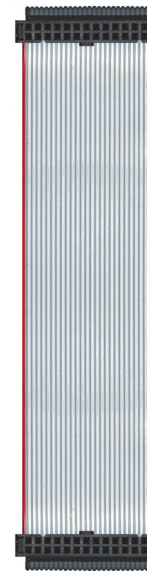
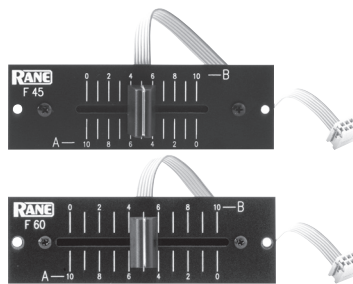

Connecting ribbon cable is included with the XP 2016a.

Accelerated-Slope and Active Crossfader are trademarks of Rane Corporation